

Container module 21, 33 & 56



Container module 21, 33 & 56



- Increases the batch volume of the conveyor.
- Elevates and further protects the filter from the conveyed product.

Technical data

Description	Unit	Value
Material		ASTM 316L
Finish	Ra	0.6

Technical data, specific

Description	Unit	Value					
		01.04.397	01.04.396	01.03.860	01.03.857	01.06.179	01.06.178
Volume	cf	0.11	0.19	0.36	0.77	1.34	3.60
Weight	lb	2.02	2.99	3.76	6.89	9.28	21.6

Ordering information

	Description	Art. No.
A	Container module 21/9	0104397
B	Container module 21/16	0104396
C	Container module 33/12	0103860
D	Container module 33/26	0103857
E	Container module 56/16	0106179
F	Container module 56/43	0106178

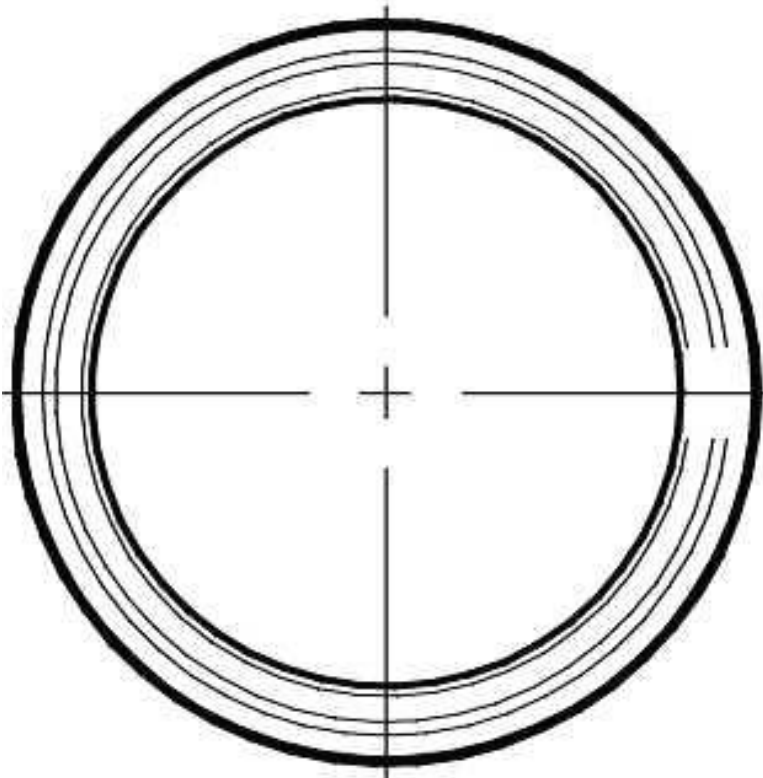
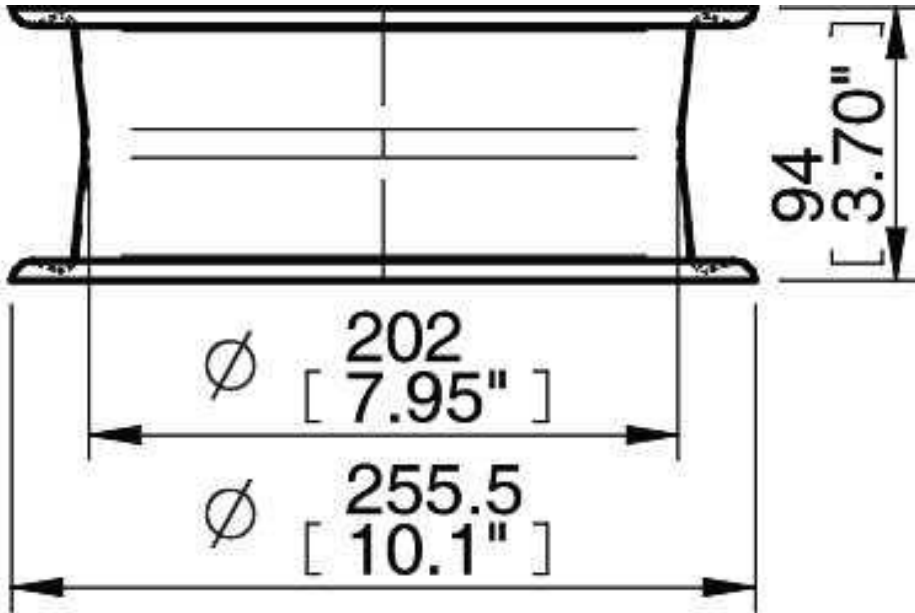

A

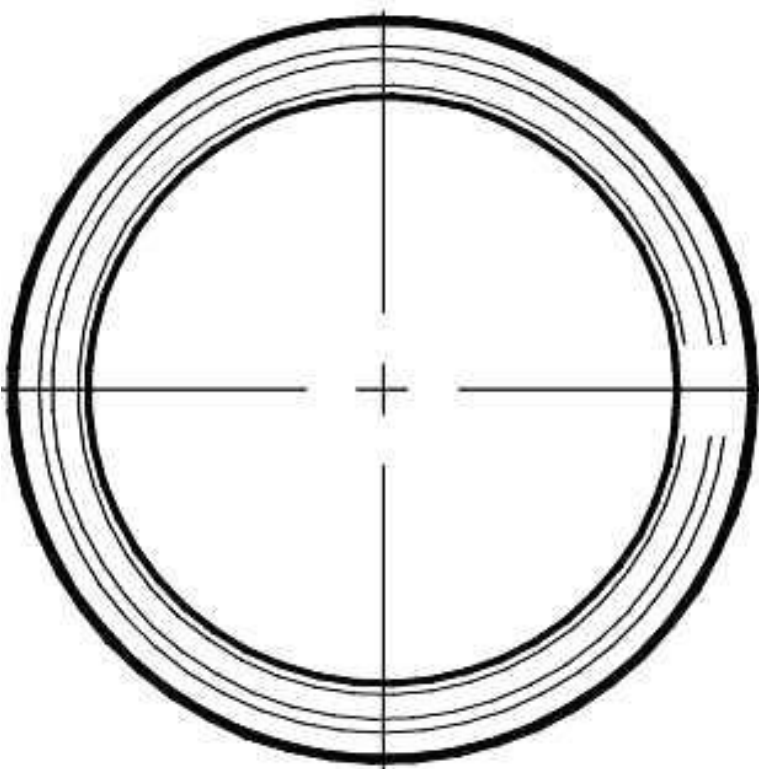
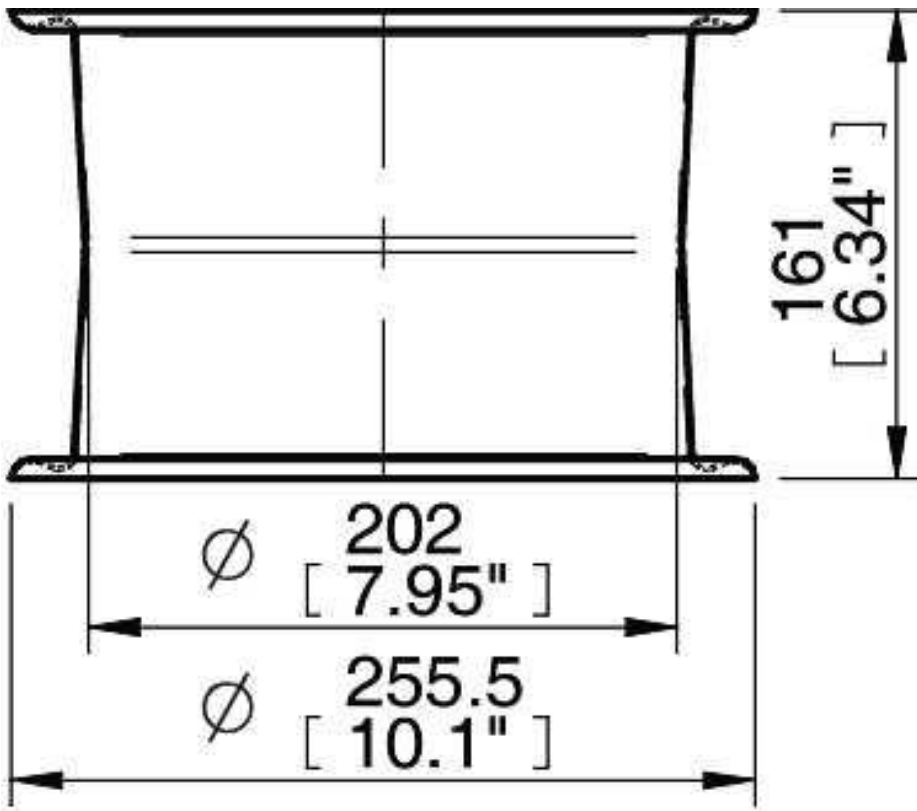

B

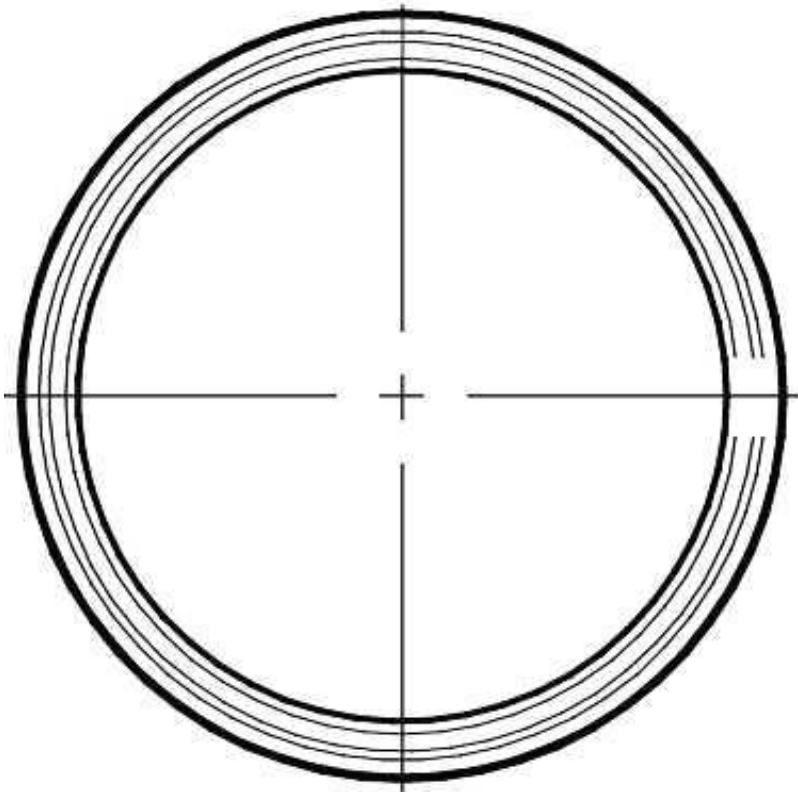
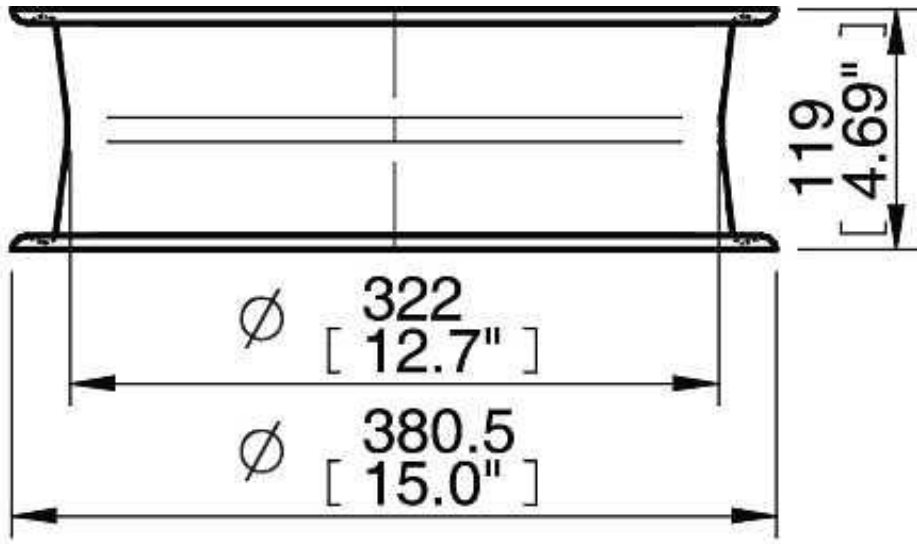

c

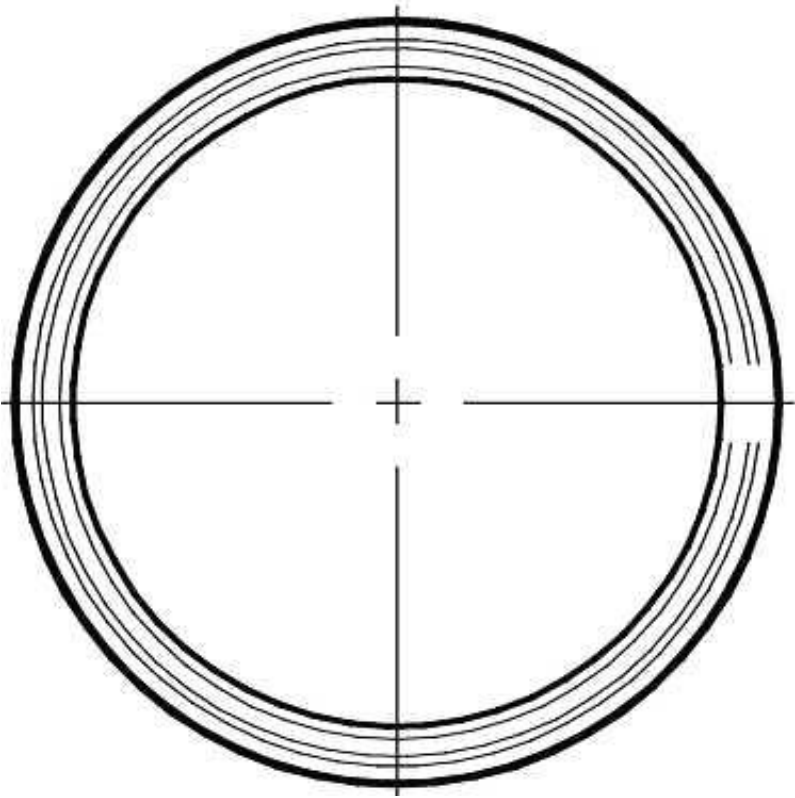
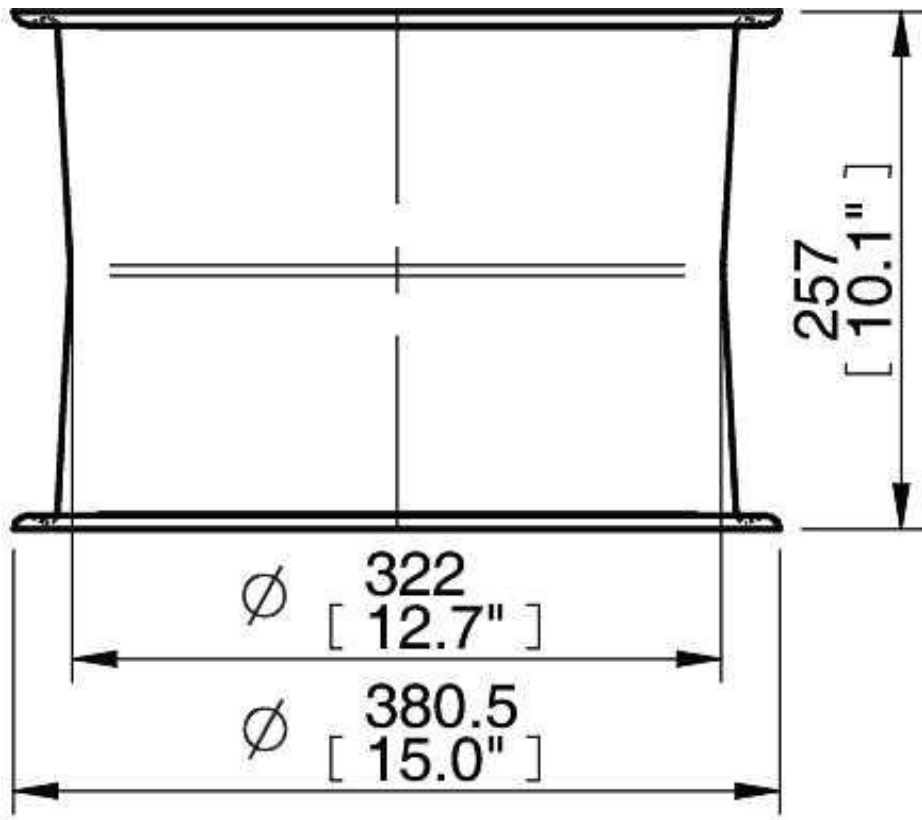

D

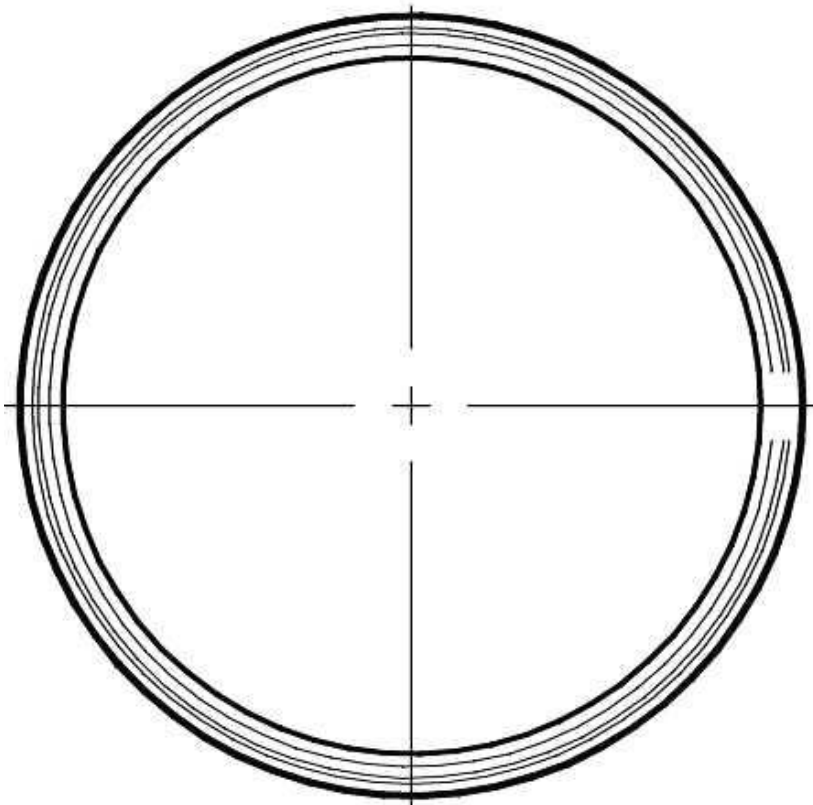
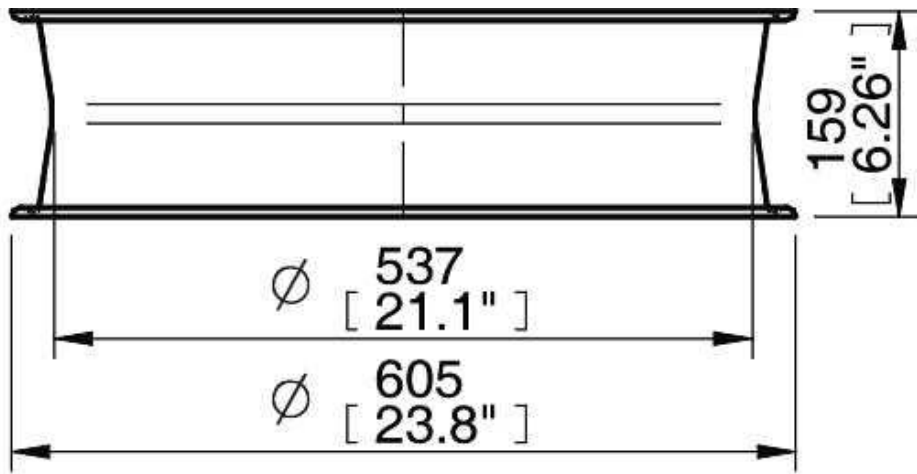

E

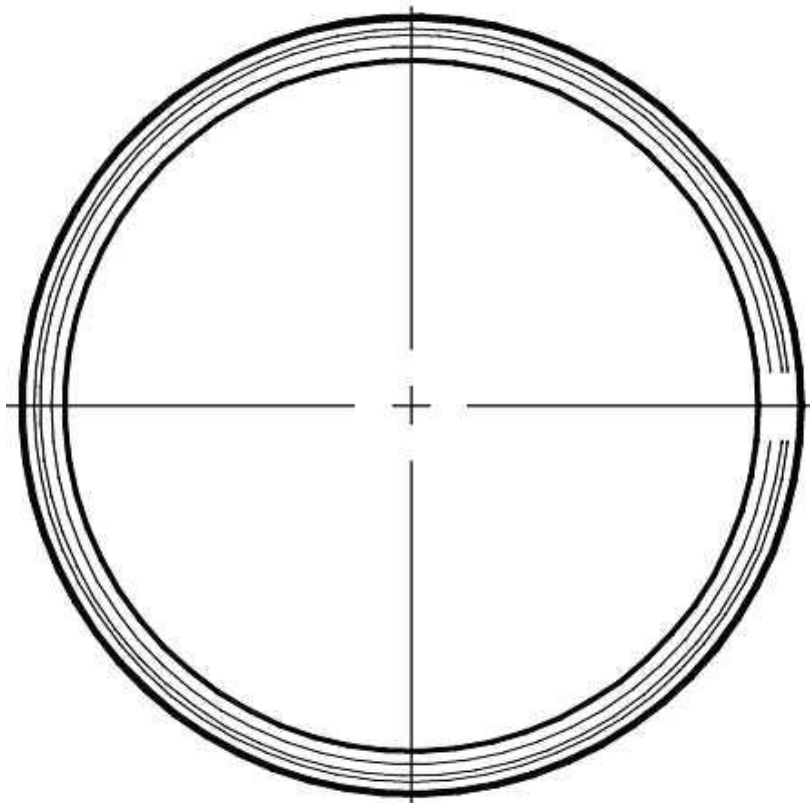
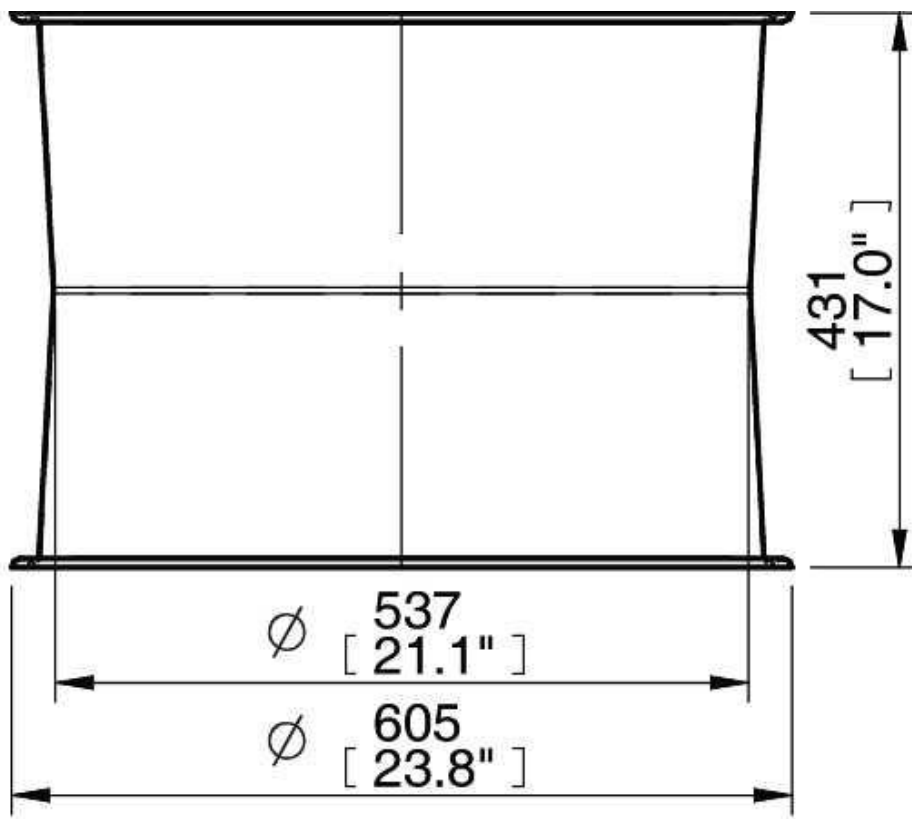

F

Ordering information,
accessories

Description	Part No.
Module seal 21 NBR	01.03.946/1
Module seal 21 Q	01.03.946/2
Clamp ring 21 cpl	01.03.972
Module seal 33 NBR	01.03.948/1
Module seal 33 Q	01.03.948/2

Clamp ring 33 cpl	01.03.977
Module seal 56 NBR	01.06.142/1
Module seal 56 Q	01.06.142/2
Clamp ring 56 cpl	01.06.127