

Container 21, 33 & 56



Container 21, 33 & 56

- Used as a receiving vessel.
- Used for pre-separation.

Technical data

Description	Unit	Value
Material		ASTM 316L
Finish	Ra	0.6

Technical data, specific

Description	Unit	Value		
		01.04.395	01.03.856	01.06.189
Volume	cf	0.11	0.44	1.96
Weight	lb	2.31	5.63	17.8

Ordering information

	Description	Part No.
A	Container 21/9	01.04.395
B	Container 33/16	01.03.856
C	Container 56/26	01.06.189

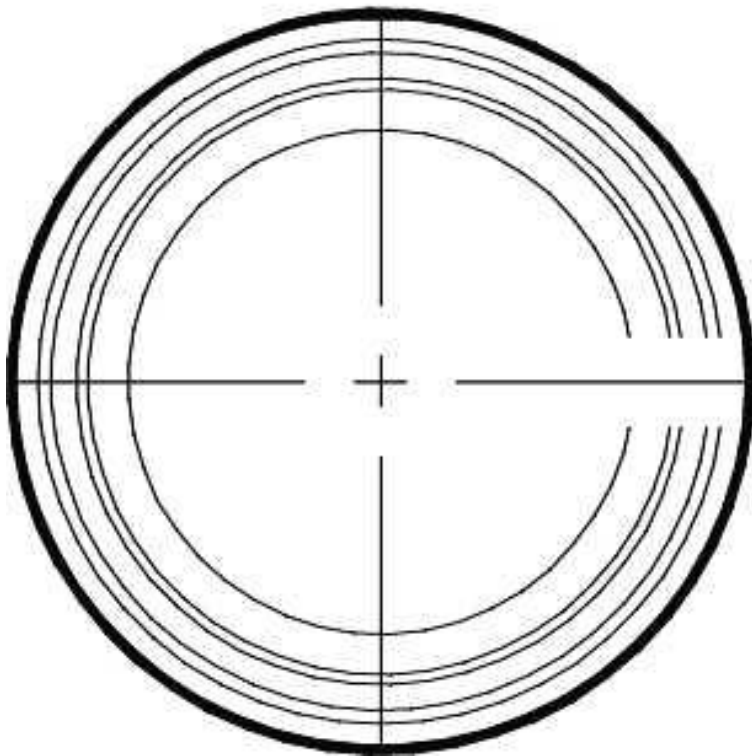
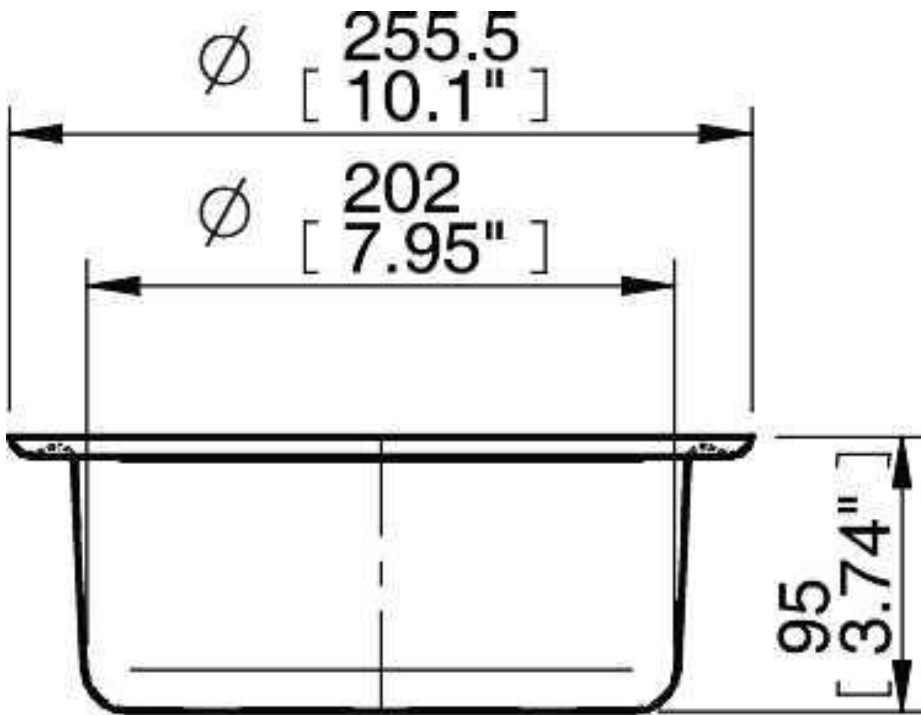

A

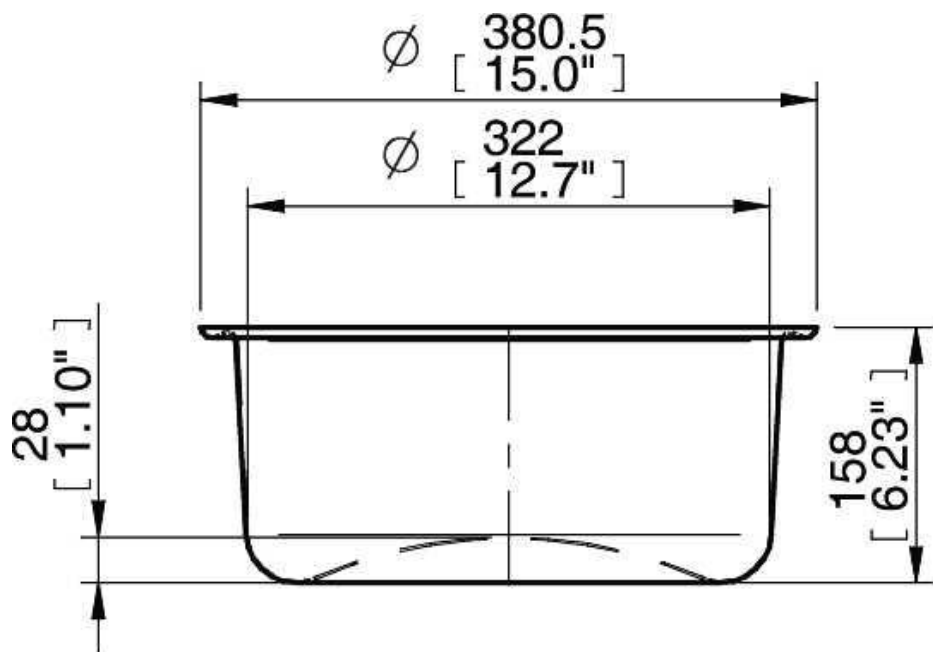

B

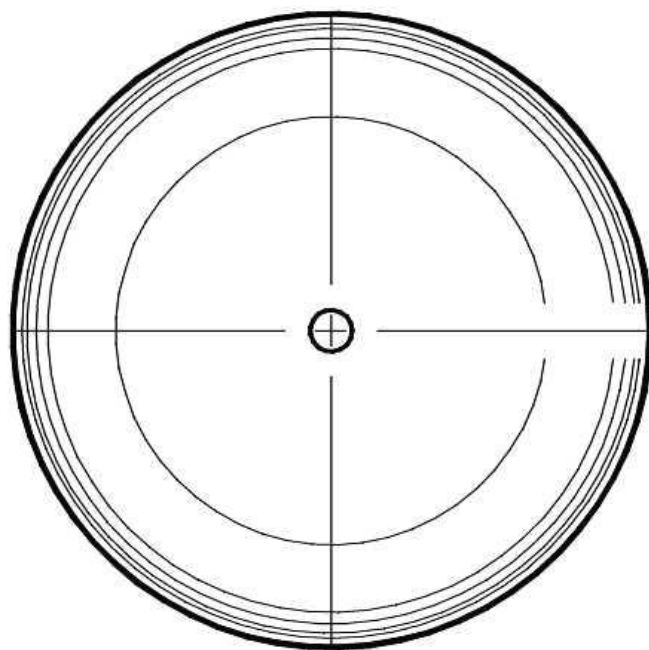
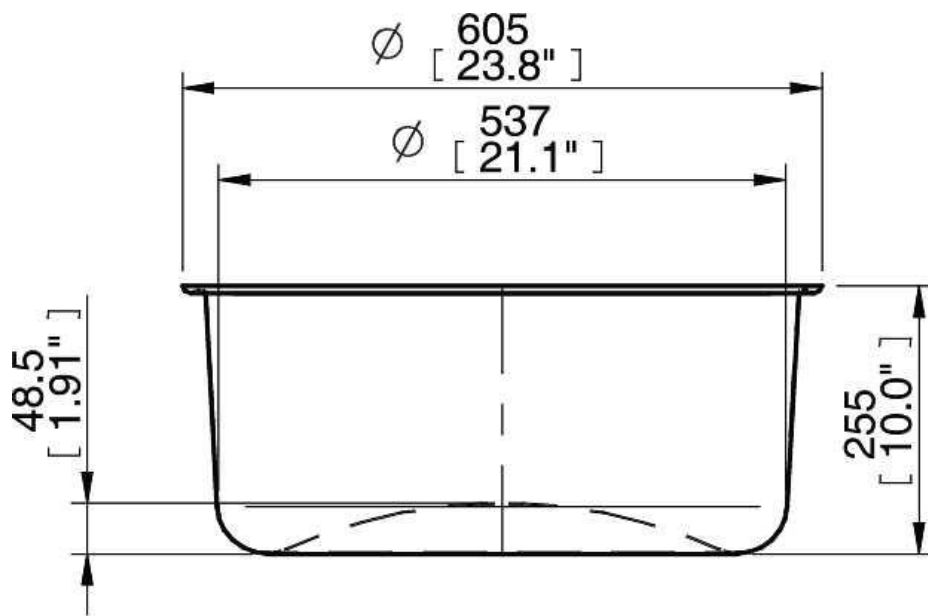

C

Ordering information,
accessories

Description	Part No.
Module seal 21 NBR	01.03.946/1
Module seal 21 Q	01.03.946/2
Clamp ring 21 cpl	01.03.972
Module seal 33 NBR	01.03.948/1
Module seal 33 Q	01.03.948/2
Clamp ring 33 cpl	01.03.977
Module seal 56 NBR	01.06.142/1
Module seal 56 Q	01.06.142/2
Clamp ring 56 cpl	01.06.127