

Level compensator LC



Level compensator LC

- Adjust differences in levels, for example on lifting devices with several suction cups.
- Less demand for exact positioning of vacuum handling device.
- Provides a certain degree of shock and vibration absorption.
- Allows for soft placement of cups on sensitive or thin objects.
- Non-rotational design, suitable for use with oval suction cups.
- Wide range of thread connections and stroke lengths.

Technical data

Description	Unit	Value
Material		Al, SS
Temperature range	°F	32-140

Technical data, specific

Part No.	Spring force lbf/in	Internal force lbf	End force lbf	Weight oz	Volume in ³	Connection	Action range/Stroke in	Max. recommended suction cup
01.27.103	1.20	0.42	0.92	0.60	0.01	M5	0.39	Ø30mm (Area: 1.09 in ²)
01.27.104	1.20	0.42	0.92	0.60	0.01	M5	0.39	Ø30mm (Area: 1.09 in ²)
01.27.105	0.69	0.45	1.12	0.81	0.01	M5	0.98	Ø30mm (Area: 1.09 in ²)
01.27.106	0.69	0.45	1.12	0.81	0.01	M5	0.98	Ø30mm (Area: 1.09 in ²)
01.24.951	1.54	0.81	2.02	1.27	0.07	G1/8"	0.79	Ø50mm (Area: 3.10 in ²)
01.24.952	1.54	0.81	2.02	1.27	0.07	G1/8"	0.79	Ø50mm (Area: 3.10 in ²)
01.24.953	0.86	0.97	2.14	1.62	0.10	G1/8"	1.38	Ø50mm (Area: 3.10 in ²)
01.24.954	0.86	0.97	2.14	1.62	0.11	G1/8"	1.38	Ø50mm (Area: 3.10 in ²)
01.24.955	1.54	0.92	2.47	2.26	0.15	G1/4"	0.98	Ø80mm (Area: 7.75 in ²)
01.24.956	1.54	0.92	2.47	2.26	0.17	G1/4"	0.98	Ø80mm (Area: 7.75 in ²)
01.24.957	0.80	0.97	2.56	3.17	0.25	G1/4"	1.97	Ø80mm (Area: 7.75 in ²)
01.24.958	0.80	0.97	2.56	3.17	0.27	G1/4"	1.97	Ø80mm (Area: 7.75 in ²)
01.24.959	1.54	1.26	3.71	5.78	0.40	G3/8"	1.57	Ø125mm (Area: 18.6 in ²)
01.24.960	1.54	1.26	3.71	5.78	0.45	G3/8"	1.57	Ø125mm (Area: 18.6 in ²)
01.24.961	0.80	1.35	3.82	8.15	0.68	G3/8"	3.15	Ø125mm (Area: 18.6 in ²)
01.24.962	0.80	1.35	3.82	8.15	0.73	G3/8"	3.15	Ø125mm (Area: 18.6 in ²)

Dimensions in

	Part No.	A	B	C	D	E	F	G	H	L	M	N	P	R	S
A	01.27.103	M5	0.22	0.67	0.98	0.33	0.31	0.22	M5	0.16	0.39	0.59	0.39	2.36	M12x1
B	01.27.104	M5	0.22	0.67	0.98	0.33	0.37	0.18	M5	0.16	0.39	0.59	0.39	2.42	M12x1
A	01.27.105	M5	0.22	0.67	1.73	0.93	0.31	0.22	M5	0.16	0.39	0.59	0.39	3.70	M12x1
B	01.27.106	M5	0.22	0.67	1.73	0.93	0.37	0.18	M5	0.16	0.39	0.59	0.39	3.76	M12X1
A	01.24.951	G1/8"	0.28	0.79	1.52	0.79	0.85	0.35	G1/8"	0.20	0.47	0.75	0.47	3.94	M16x1
B	01.24.952	G1/8"	0.28	0.79	1.52	0.79	0.71	0.20	G1/8"	0.20	0.47	0.75	0.47	3.80	M16x1
A	01.24.953	G1/8"	0.28	0.79	2.30	1.38	0.85	0.35	G1/8"	0.20	0.47	0.75	0.47	5.31	M16x1
B	01.24.954	G1/8"	0.28	0.79	2.30	1.38	0.71	0.20	G1/8"	0.20	0.47	0.75	0.47	5.18	M16X1
A	01.24.955	G1/4"	0.39	0.91	1.97	0.98	0.59	0.39	G1/4"	0.24	0.63	0.94	0.63	4.45	M20x1.5
B	01.24.956	G1/4"	0.39	0.91	1.97	0.98	0.55	0.26	G1/4'	0.24	0.63	0.94	0.63	4.41	M20x1.5
A	01.24.957	G1/4"	0.39	0.91	3.25	1.97	0.59	0.39	G1/4"	0.24	0.63	0.94	0.63	6.71	M20X1.5
B	01.24.958	G1/4"	0.39	0.91	3.25	1.97	0.55	0.26	G1/4'	0.24	0.63	0.94	0.63	6.67	M20x1.5
A	01.24.959	G3/8"	0.43	1.30	2.80	1.57	0.59	0.43	G3/8"	0.31	0.87	1.26	0.87	6.26	M25x1.5
B	01.24.960	G3/8"	0.43	1.30	2.80	1.57	0.71	0.37	G3/8"	0.31	0.87	1.26	0.87	6.38	M25x1.5
A	01.24.961	G3/8"	0.43	1.30	4.76	3.15	0.59	0.43	G3/8"	0.31	0.87	1.26	0.87	9.80	M25x1.5
B	01.24.962	G3/8"	0.43	1.30	4.76	3.15	0.71	0.37	G3/8"	0.31	0.87	1.26	0.87	9.92	M25x1.5

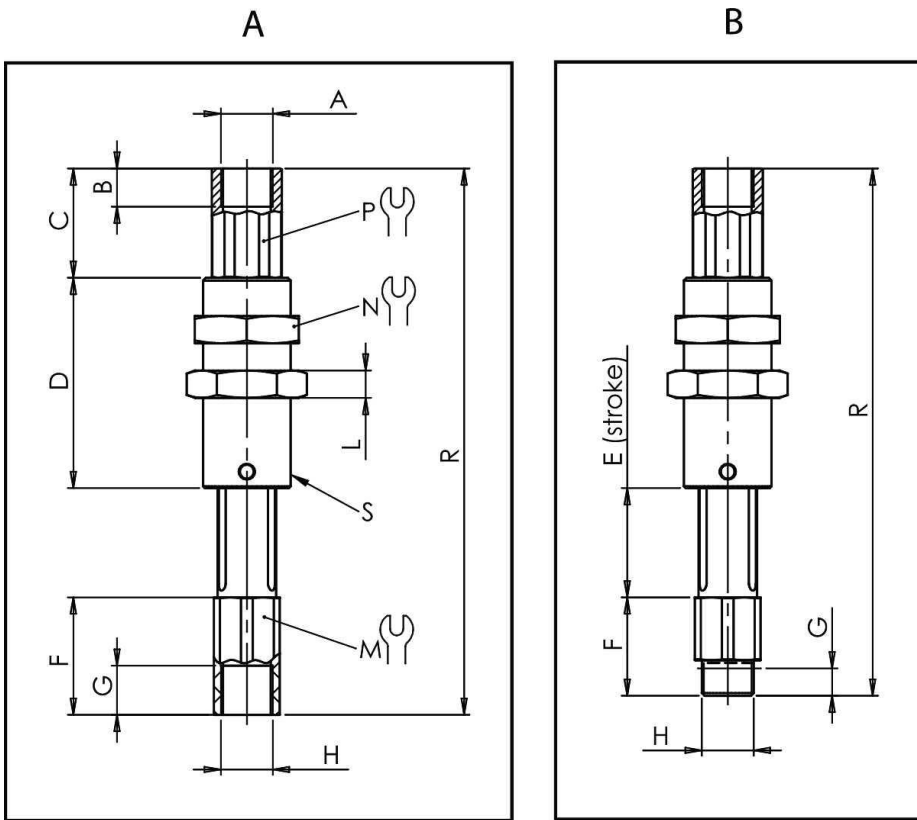

Ordering information

Description	Part No.
Level compensator LC12-F0510	01.27.103
Level compensator LC12-M0510	01.27.104
Level compensator LC12-F0525	01.27.105
Level compensator LC12-M0525	01.27.106
Level compensator LC16-F1820	01.24.951
Level compensator LC16-M1820	01.24.952
Level compensator LC16-F1835	01.24.953
Level compensator LC16-M1835	01.24.954
Level compensator LC20-F1425	01.24.955
Level compensator LC20-M1425	01.24.956
Level compensator LC20-F1450	01.24.957
Level compensator LC20-M1450	01.24.958
Level compensator LC25-F3840	01.24.959
Level compensator LC25-M3840	01.24.960
Level compensator LC25-F3880	01.24.961
Level compensator LC25-M3880	01.24.962