

piPREMIUM upgrade kit C33-1200



piPREMIUM upgrade kit C33-1200

- The kit is a plug-and-play assembly for a quick changeover to replace the Maxi L pump and top module
- COAX® patented technology
- Side mounted for low building height
- High vacuum flow
- Compact size and low weight
- Low noise level
- Modular design
- Pneumatic valve for compressed air to shock tank and mounting plate for the C series are included

Technical data

Description	Unit	Value
Material		ASTM 316L, AI, SS, PA, PP, NBR
Temperature range	°F	32-140
Weight	lb	46.2
Feed pressure, max.	psi	101.5
Feed pressure, range	psi	58-87
Air consumption, range	scfm	127-178
Vacuum range	-inHg	18-22
Noise level	dBA	69-77

Vacuum flow piPREMIUM1200

Feed pressure*	Air consumption	Vacuum flow (scfm) at different vacuum levels (-inHg)									Max vacuum
		0	3	6	9	12	15	18	21	-inHg	
58	127	509	295	193	123	80.5	40.7	10.2	—	18.0	
72.5	153	614	335	225	142	86.9	63.6	35.6	18.2	21.0	
87	178	610	356	265	174	91.1	61.4	50.9	35.6	22.2	

*Feed pressure tolerance, +/- 1.45 psi

Ordering information

Description

piPREMIUM upgrade kit C33-1200

Part No.

02.01.126

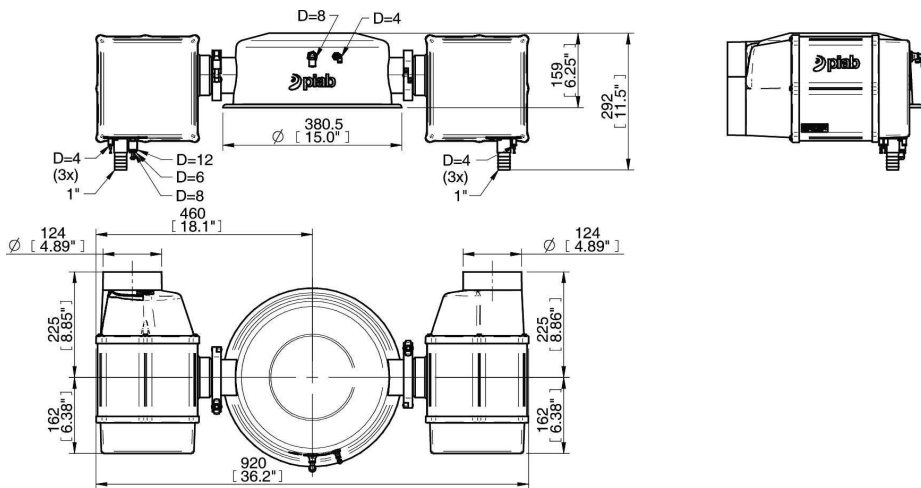

Ordering information, accessories

Description

Regulator kit piFLOW®p 1" 1200-1600 (0104491 x2)

Part No.

02.01.782

Wall mounting kit pump piPREMIUM 1200-1600 (0201025 x2)

02.01.786

Maintenance kit piFLOW® pumps

02.01.649