

# Sterile filter units piFLOW®p



## Sterile filter units piFLOW®p



- Secondary sterile filter for piFLOW®p conveyor family
- FDA approved
- Easy to assemble / disassemble
- Complete kit, ready to use

### Technical data

Description	Unit	Value
Material		SS, Borosilicate, Silicone, PDMS, ASTM 316L, EPDM
Temperature range	°C	0-60
Min particle size	µm	0.2

### Technical data, specific

Description	Unit	Value			
		0201717	0201690	0201691	0201692
Weight	kg	2.5	7.8	15.5	23.8
Connection	mm	TC33.7 flange Ø50.5	TC63.5 flange Ø77.5 and hose Ø63.5	TC63.5 flange Ø77.5 and hose Ø63.5	TC76.2 flange Ø91 and hose Ø76
Filter area	m <sup>2</sup>	0.4	0.6	1.7	2.5
Finish, wall mounting bracket	Ra	n/a	3.2	3.2	3.2
Finish, sterile filter	Ra	0.8	1.6	1.6	1.6

### Pressure drop

Description	Unit	Value			
		0201717	0201690	0201691	0201692
Pressure drop	kPa	2.9	4.3	3.0/4.9	8.5/9.6
Pump	n/a	P64	P100	P200/P400	P600/P800

Ordering information

	Description	Art. No.
A	Sterile filter unit P64	0201717
B	Sterile filter unit P100	0201690
C	Sterile filter unit P200-400	0201691
D	Sterile filter unit P600-800	0201692

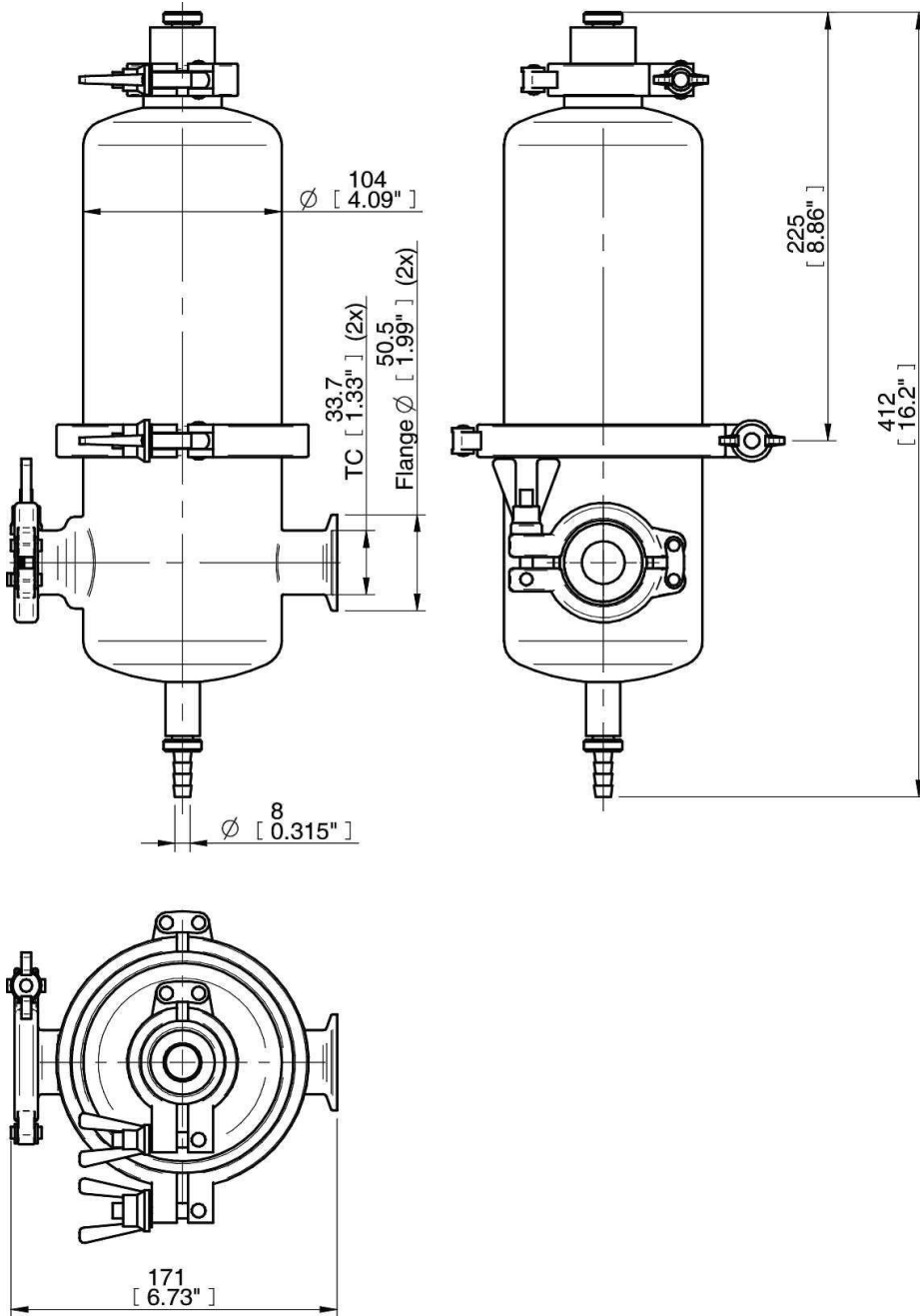

A

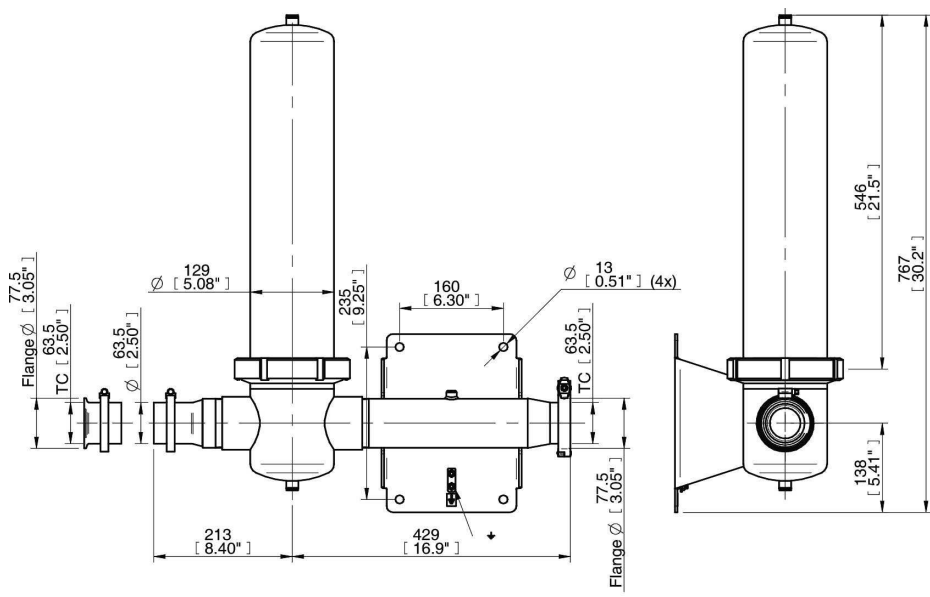
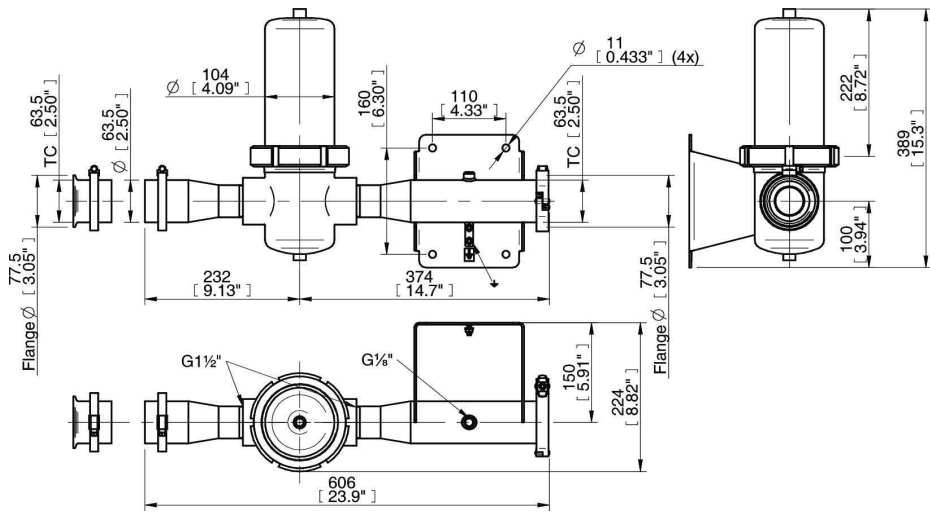

B

C

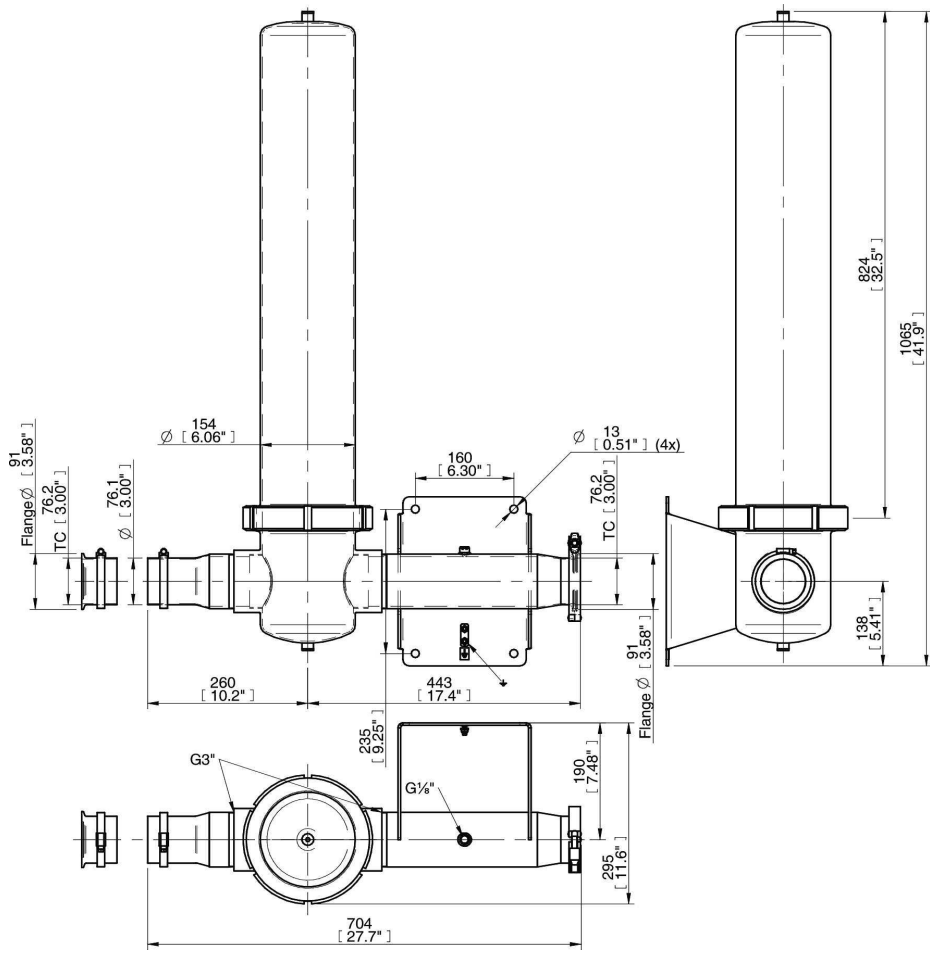

D