

Technische Zeichnung | Технический чертёж

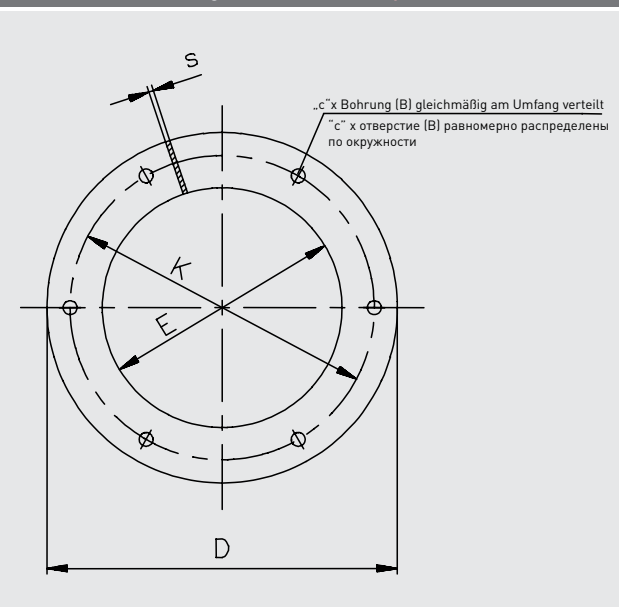

Optionen | Опции



gebohrt nach DIN 24154, T2  
 отверстия по DIN 24154, T2

DN	s	D	E	K	C	B
80	6	144	84	118	4	9,5
100	6	165	105	139	4	9,5
120	6	185	125	155	4	9,5
150	6	225	155	191	8	11,5
175	6	250	180	215	8	11,5
200	6	275	205	241	8	11,5
250	6	326	256	292	8	11,5
300	8	385	305	349	8	11,5
350	8	435	355	399	8	11,5
400	8	488	408	448	12	11,5
450	8	537	457	497	12	11,5
500	8	587	507	551	12	11,5
550	8	655	555	605	16	14
600	8	705	605	665	16	14

	pulverbeschichtet порошков.покр.	verzinkt оцинк.	1.4301 1.4301
	Art.-Nr. Арт.-№	Art.-Nr. Арт.-№	Art.-Nr. Арт.-№
DN 80	0801054	0802054	0803054
DN 100	1001054	1002054	1003054
DN 120	1201054	1202054	1203054
DN 150	1501054	1502054	1503054
DN 175	1701054	1702054	1703054
DN 200	2001054	2002054	2003054
DN 250	2501054	2502054	2503054
DN 300	3001054	3002054	3003054
DN 350	3551054	3552054	3553054
DN 400	4051054	4052054	4053054
DN 450	4551054	4552054	4553054
DN 500	5051054	5052054	5053054
DN 550	5551054	5552054	5553054
DN 600	6051054	6052054	6053054